

---

## 525.749 Image Compression, Packet Video and Video Processing

Dr. Nicholas Beser

E-mail: [Nicholas.Beser@jhuapl.edu](mailto:Nicholas.Beser@jhuapl.edu)

9/21/09

Lecture 2 – Fourier Analysis of Video Signals & Frequency Response of the HVS

<http://webdev.apl.jhu.edu/~beser/525759/index.html>

1

## Outline

- 
- **Fourier transform over multidimensional space**
    - Continuous space FT (CSFT)
    - Discrete space FT (DSFT)
    - Sampled space FT (SSFT)
  - **Frequency domain characterization of video signals**
    - Spatial frequency
    - Temporal frequency
    - Temporal frequency caused by motion
  - **Frequency response of the HVS**
    - Spatial frequency response
    - Temporal frequency response and flicker
    - Spatio-temporal response
    - Smooth pursuit eye movement

2

## Continuous Space Signals

- **K-D Space Signals**

$$\psi(x), x = [x_1, x_2, \dots, x_k] \in R^k$$

- **Convolution**

$$\psi(x) * h(x) = \int_{R^k} \psi(x-y)h(y)dy$$

- **Example function**

- Delta function

3

## Continuous Space Fourier Transform (CSFT)

- **Forward transform**

$$\Psi_c(f) = \int_{R^k} \psi(x) \exp(-j2\pi f^T x) dx$$

- **Inverse transform**

$$\psi(x) = \int_{R^k} \Psi_c(f) \exp(j2\pi f^T x) df$$

- **Convolution theorem**

$$\psi(x) * h(x) \Leftrightarrow \Psi_c(f) H_c(f)$$

$$\psi(x)h(x) \Leftrightarrow \Psi_c(f) * H_c(f)$$

4

## Continuous Space Systems

- **General system over K-D continuous space**

$$\phi(x) = T(\psi(x)), x \in R^k$$

- **Linear and Space-Shift Invariant (LSI) System**

$$\alpha_1\phi_1(x) + \alpha_2\phi_2(x) = T(\alpha_1\psi_1(x) + \alpha_2\psi_2(x))$$

$$T(\psi(x + x_0)) = \phi(x + x_0)$$

- **LSI systems can be completely described by its impulse response**

$$h(x) = T(\delta(x))$$

$$\phi(x) = \psi(x) * h(x) \Leftrightarrow \Phi_c(f) = \Psi_c(f)H_c(f)$$

5

## Discrete Space Signals

- **K-D Space Signals**

$$\psi(n), n = [n_1, n_2, \dots, n_k] \in Z^k$$

- **Convolution**

$$\psi(n) * h(n) = \sum_{m \in Z^k} \psi(n-m)h(m)$$

- **Example function**

- Delta function

6

## Discrete Space Fourier Transform (DSFT)

- **Forward transform**

$$\Psi_d(f) = \sum_{n \in R^k} \psi(n) \exp(-j2\pi f^T n)$$

$\Psi_d(f)$  is periodic in each dimension with period of 1

Fundamental period:  $I^K = \{f, f_k \in (-1/2, 1/2)\}$

- **Inverse transform**

$$\psi(n) = \int_{f \in I^k} \Psi_d(f) \exp(j2\pi f^T n) df$$

- **Convolution theorem**

$$\psi(n) * h(n) \Leftrightarrow \Psi_d(f) H_d(f)$$

$$\psi(n) h(n) \Leftrightarrow \Psi_d(f) * H_d(f)$$

7

## Outline

- **Fourier transform over multidimensional space**
  - Continuous space FT (CSFT)
  - Discrete space FT (DSFT)
  - Sampled space FT (SSFT)
- **Frequency domain characterization of video signals**
  - Spatial frequency
  - Temporal frequency
  - Temporal frequency caused by motion
- **Frequency response of the HVS**
  - Spatial frequency response
  - Temporal frequency response and flicker
  - Spatio-temporal response
  - Smooth pursuit eye movement

8

## Spatial Frequency

- Spatial frequency measures how fast the image intensity changes in the image plane
- Spatial frequency can be completely characterized by the variation frequencies in two orthogonal directions (e.g horizontal and vertical)
  - $f_x$ : cycles/horizontal unit distance
  - $f_y$ : cycles/vertical unit distance
- It can also be specified by magnitude and angle of change

$$f_m = \sqrt{f_x^2 + f_y^2}, \theta = \arctan(f_y / f_x)$$

9

## Illustration of Spatial Frequency

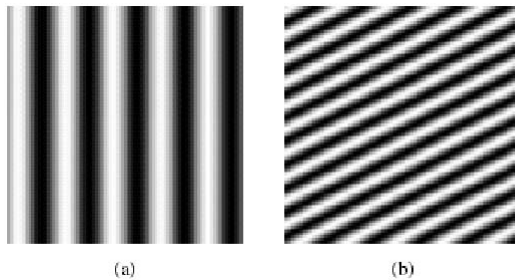
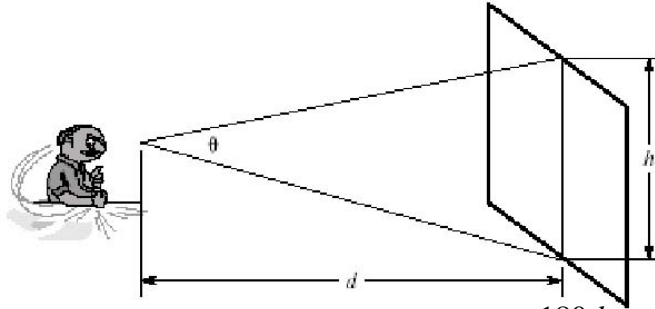

Figure 2.1 Two-dimensional sinusoidal signals: (a)  $(f_x, f_y) = (5, 0)$ ; (b)  $(f_x, f_y) = (5, 10)$ . The horizontal and vertical units are the width and height of the image, respectively. Therefore,  $f_x = 5$  means that there are five cycles along each row.

10

## Angular Frequency

Problem with previous defined spatial frequency:  
Perceived speed of change depends on the viewing distance.



$$\theta = 2 \arctan(h/2d) (\text{radian}) \approx h/2d (\text{radian}) = \frac{180}{\pi} \frac{h}{d} (\text{degree})$$

$$f_{\theta} = \frac{f_s}{\theta} = \frac{\pi}{180} \frac{d}{h} f_s (\text{cycle/degree})$$

11

## Temporal Frequency

- Temporal frequency measures temporal variation (cycles/s)
- In a video, the temporal frequency is spatial position dependent, as every point may change differently
- Temporal frequency is caused by camera or object motion

12

## Temporal Frequency caused by Linear Motion

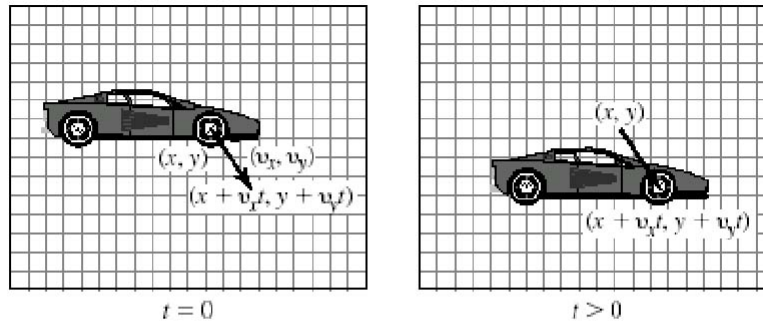

**Figure 2.3** Illustration of the constant intensity assumption under motion. Every point  $(x, y)$  at  $t = 0$  is shifted by  $(v_x t, v_y t)$  to  $(x + v_x t, y + v_y t)$  at time  $t$ , without change in color or intensity. Alternatively, a point  $(x, y)$  at time  $t$  corresponds to a point  $(x - v_x t, y - v_y t)$  at time zero.

## Relation between Motion, Spatial and Temporal Frequency

$$\psi(x, y, t) = \psi_0(x - v_x t, y - v_y t) \Leftrightarrow$$

$$\Psi(f_x, f_y, f_t) = \Psi_0(f_x, f_y) \delta(f_t + v_x f_x + v_y f_y)$$

**Relation between motion, spatial, and temporal frequency:**

$$f_t = -(v_x f_x + v_y f_y)$$

**Example:**

**An plane with vertical bar pattern, moving vertically, causes no temporal change;**

**But moving horizontally, it causes fastest temporal change**

## Illustration of the Relation

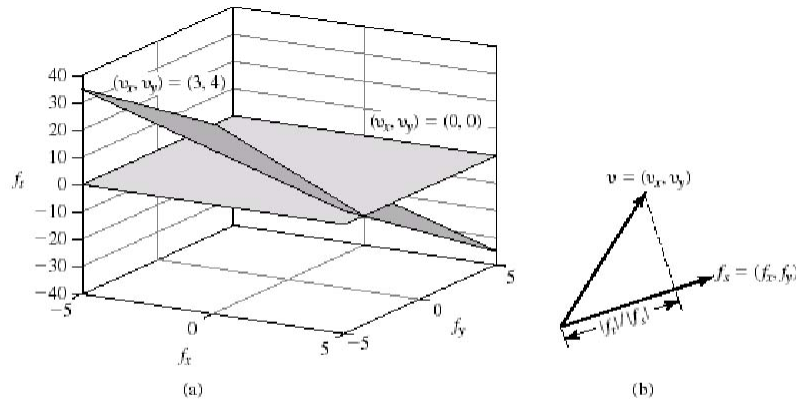

**Figure 2.4** Relation between spatial and temporal frequencies under linear motions. (a) The spatiotemporal frequency plane in the  $(f_x, f_y, f_t)$  space, corresponding to two different velocity vectors; (b) the temporal frequencies is equal to the projection of the velocity onto the spatial gradient.

## Outline

- **Fourier transform over multidimensional space**
  - Continuous space FT (CSFT)
  - Discrete space FT (DSFT)
  - Sampled space FT (SSFT)
- **Frequency domain characterization of video signals**
  - Spatial frequency
  - Temporal frequency
  - Temporal frequency caused by motion
- **Frequency response of the HVS**
  - Temporal frequency response and flicker
  - Spatial frequency response
  - Spatio-temporal response
  - Smooth pursuit eye movement

## Temporal Response

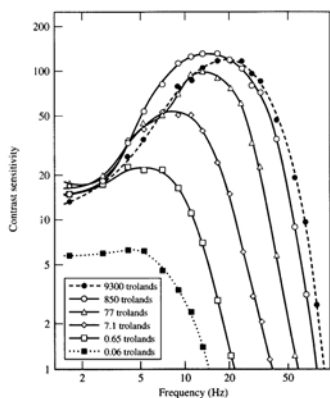

Figure 2.5 The temporal frequency response of the HVS obtained by a visual experiment. Different curves represent the responses obtained with different mean brightness levels,  $B$ , measured in trolands. The horizontal axis represents the flicker frequency  $f$ , measured in Hz. Reprinted from D. H. Kelly, Visual responses to time-dependent stimuli. I. Amplitude sensitivity measurements, *J. Opt. Soc. Am.* (1961) 51:422-29, by permission of the Optical Society of America.

- **Critical flicker frequency:** The lowest frame rate at which the eye does not perceive flicker.
- Provides guideline for determining the frame rate when designing a video system.
- Critical flicker frequency depends on the mean brightness of the display:
- 60 Hz is typically sufficient for watching TV.
- Watching a movie needs lower frame rate than TV

17

## Spatial Response

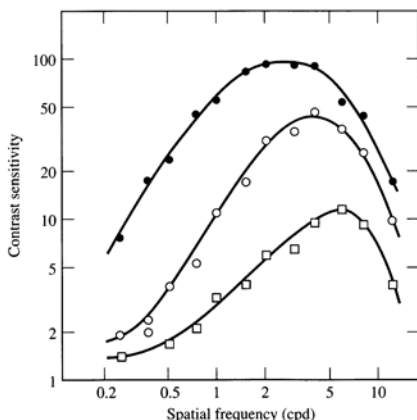
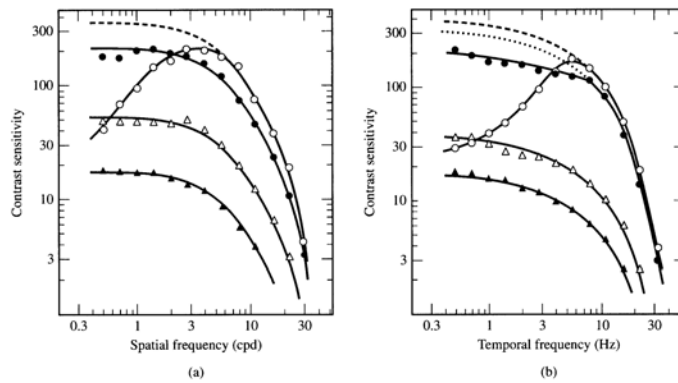

Figure 2.6 The spatial frequency response of the HVS, obtained by a visual experiment. The three curves result from different stabilization settings used to remove the effect of saccadic eye movements. Filled circles were obtained under normal, unstabilized conditions; open squares, with optimal gain setting for stabilization; open circles, with the gain changed about 5 percent. Reprinted from D. H. Kelly, Motion and vision. I. Stabilized images of stationary gratings, *J. Opt. Soc. Am.* (1979), 69:1266-74, by permission of the Optical Society of America.

18

## Spatiotemporal Response



**Figure 2.7** Spatiotemporal frequency response of the HVS. (a) Spatial frequency responses for different temporal frequencies of 1 Hz (open circles), 6 Hz (filled circles), 16 Hz (open triangles), and 22 Hz (filled triangles). (b) Temporal frequency responses for different spatial frequencies of 0.5 cpd (open circles), 4 cpd (filled circles), 16 cpd (open triangles), and 22 cpd (filled triangles). Reprinted from J. G. Robson, Spatial and temporal contrast sensitivity functions of the visual systems, *J. Opt. Soc. Am.* (1966), 56:1141–42, by permission of the Optical Society of America.

The reciprocal relation between spatial and temporal sensitivity was used in TV systems design: Interlaced scan provides tradeoff between spatial and temporal resolution

## Smooth Pursuit Eye Movement

- **Smooth Pursuit:** the eye tracks moving objects
- **Net effect:** reduce the velocity of moving objects on the retinal plane, so that the eye can perceive much higher raw temporal frequencies than indicated by the temporal frequency response.

- Temporal frequency caused by object motion when the object is moving at  $(v_x, v_y)$ :

$$f_t = -(v_x f_x + v_y f_y)$$

- Observed temporal frequency at the retina when the eye is moving at  $(\tilde{v}_x, \tilde{v}_y)$ :

$$\tilde{f}_t = f_t + (\tilde{v}_x f_x + \tilde{v}_y f_y)$$

$$\tilde{f}_t = 0 \text{ if } \tilde{v}_x = v_x, \tilde{v}_y = v_y$$

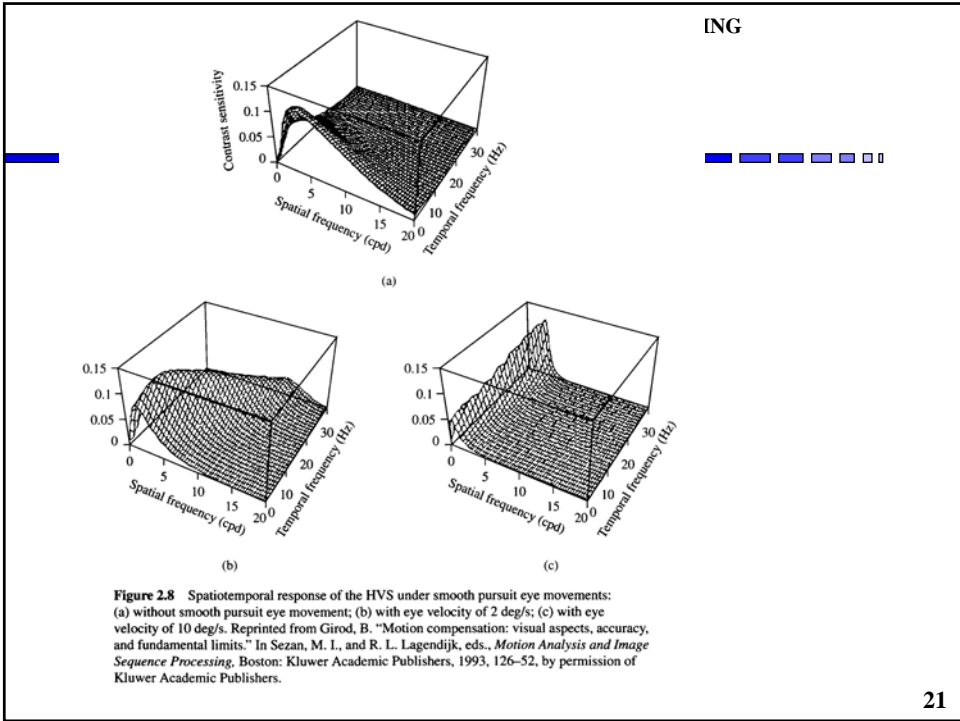

IMAGE COMPRESSION, PACKET VIDEO AND VIDEO PROCESSING

## Video Sampling – A Brief Discussion

---

- Review of Nyquist sampling theorem in 1-D
- Extension to multi-dimensions
- Prefilter in video cameras
- Interpolation filter in video displays

22

## Nyquist Sampling Theorem in 1-D

- Given a band-limited signal with maximum frequency  $f_{max}$ , it can be sampled with a sampling rate  $f_s \geq 2f_{max}$ . The original continuous signal can be reconstructed (interpolated) from the samples exactly, by using an ideal low pass filter with cut-off frequency at  $f_s/2$ .
- Practical interpolation filters: replication (sample-and-hold, 0<sup>th</sup> order), linear interpolation (1<sup>st</sup> order), cubic-spline (2<sup>nd</sup> order)
- Given the maximally feasible sampling rate  $f_s$ , the original signal should be bandlimited to  $f_s/2$ , to avoid aliasing. The desired prefilter is an ideal low-pass filter with cut-off frequency at  $f_s/2$ .
- Prefilter design: Trade-off between aliasing and loss of high frequency

23

## Extension to Multi-dimensions

- If the sampling grid is aligned in each dimension (rectangular in 2-D) and one performs sampling in each dimension separately, the extension is straightforward:
  - Requirement:  $f_{s,i} \leq f_{max,i}/2$
  - Interpolation/pre-filter: ideal low-pass in each dimension
- If the sampling grid is an arbitrary lattice, the support region of the signal spectrum must be limited within the Voronoi region of the reciprocal of the sampling lattice
  - See Chapters 3 and 4 for sampling and sampling-rate conversion for K-D signals and for video in particular
  - Interlaced scan uses a non-rectangular lattice in the vertical-temporal plane.

24

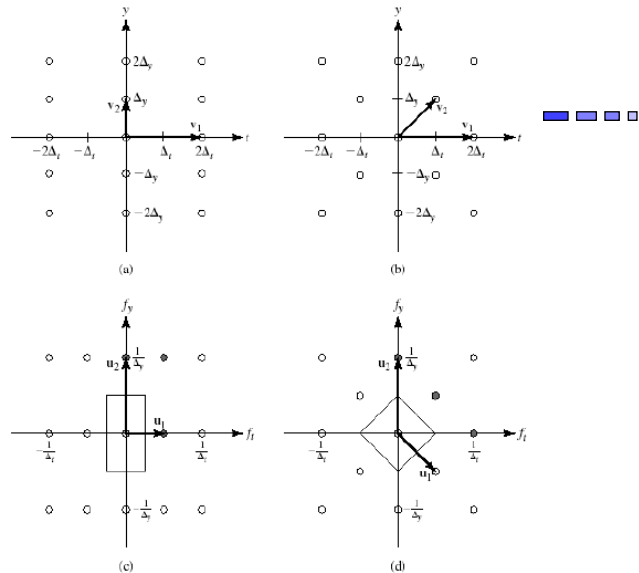

Figure 3.6 Comparison of progressive and interlaced scans: (a) sampling lattice for progressive scan; (b) sampling lattice for interlaced scan; (c) reciprocal lattice for progressive scan; (d) reciprocal lattice for interlaced scan. Filled circles in (c) and (d) indicate the nearest aliasing components.

## Video Cameras

- **Sampling mechanism**
  - All perform sampling in time
  - Film cameras capture continuous frames on film
  - Analog video cameras sample in vertical but not horizontal direction, arrange the resulting horizontal scan lines in a 1-D continuous signal
  - Digital cameras sample in both horizontal and vertical direction, yielding pixels with discrete 3-D coordinates
- **Sampling frequency (frame rate and line rate)**
  - Depending on the maximum frequency in the underlying signal, the human visual thresholds, as well as technical feasibility and cost
- **Prefilter**
  - Controlled by temporal exposure, scanning beam, etc.
  - Digital cameras may capture at higher sampling rates and then implement explicit filtering before converting to lower resolution

## Typical Camera Response

- **Temporal prefilter:** the value read out at any frame is the average of the sensed signal over the exposure time
- **Spatial prefilter:** the value read out at any pixel is a weighted integration of the signal in a small window surrounding it, called the aperture, can be approximated by a box average or a 2-D Gaussian function

27

## Video Display

- The display device presents the analog or digital video on the screen to create the sensation of continuously varying signal in both time and space.
- With CRT, three electronic beams strike red, green, and blue phosphors with the desired intensity at each pixel location. No explicit interpolation filters are used. Spatial filtering determined by the size of the scanning beam, temporal filtering determined by the decaying time of the phosphors.
- The eye performs the interpolation task: fuses discrete frames and pixels as continuously varying, if the temporal and spatial sampling rates are sufficiently high.

28

## Homework #2

- **Reading Assignment:**
  - Chapter 5
- **Problems: (Due October 5, 2009)**
  - 2.1
  - 2.2
  - 2.5
  - **MATLAB Problem:** The class web page will have a two data files that you should read into the computer. The files are NTSC images (640x480x24bit). For each data file: Show the complete image. Deinterlace the image and show the two fields as two separate images. Compare the two field images (compute a mean squared error measure). Discuss your observations. (Hint, these are two stationary scenes). Submit your MATLAB scripts and the print from each image.

29

## Homework #2 Continued

- **MATLAB Problem:** Calibration of a video system typically is performed by presenting the camera with targets of known patterns, where the signal response can be measured. Two targets: SMPTE Bars, and Multiburst are used to show the color calibration and frequency response of the system.
- The SMPTE bars image shown on the next pages is on the Resources html page of the class website. The Multiburst image (also on the web page is on the same web page. The Multiburst waveform can be simulated using:
- for i=1:row
- th=1;
- th\_mult=1;
- for j=1:cols
- testing(i,j)=sin(th\*th\_mult^2)+1;
- th\_mult=th\_mult+inc\*multix;
- end
- end
- where row is the number of rows in the image, cols is the number of columns and multix is a frequency multiplier (I use 3 for 512x512). Inc is computed from:
- $inc=(2*\pi)/(rows-1);$

30

## Homework #2 Continued

- Generate a multiburst image (use 512x512) and compute and plot the FFT of a row from the image. Also compute and plot the 2D fft of the entire image.
- It may be easier to display by subtracting the mean of the row and mean of the image. Note, this image will be used in a later homework assignment, so save the image as a 16 bit, PNG file.
- Hint: use `imwrite(uint16(img/max(max(img))), 'filename.png', 'png');`
- Load the SMPTE Bars image into MATLAB from the YUV data file. Load the SMPTE Bars image into MATLAB from the RGB data file, and then perform a MSE error comparison of the two files by converting the YUV file to RGB. Do not round the RGB values to 8 bits in your conversion.

31

## SMPTE Bars



32

## Multiburst Image

